

FILTER SCREEN HC

“ The FILTER SCREEN HC is designed for the filtration of liquids or mud containing 5 to 10% of solid particles to be extracted. It can be used for safety filtering. ”



1 | CUSTOMIZED DESIGN

All design criteria such as speed, cuts, particle size distribution, food compatibility, temperature, etc. are integrated to design our machines (surface, amplitude, frequency of vibration, slope, cloths, etc.).

➔ **Options** : Feeding box (TC version) and filtered liquids collector (BC version).

2 | APPLICATIONS

- **Drilling** : removal of sand and stones in the drilling mud used to lubricate drill bits.
- **Food** :
 - sugar industry
 - oil works
 - canning industry
- **Chemical**
- **Paper industry**

3 | USES

- **PRE-FILTRATION** before other processes : decanting machine, centrifuge, filterpress, purifier, etc.
- **FILTERING** of any liquid or mud containing solid particles to be eliminated or sorted-out.

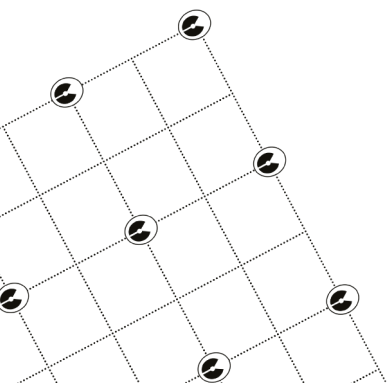



10 **DECLOGGING SYSTEM**
• BIL-VIB (balls)



11 **VIBRATING BODY**
• Welded until 0,9m²
• Bored, assembled and bolted

• Fully removable
• Steel or stainless steel

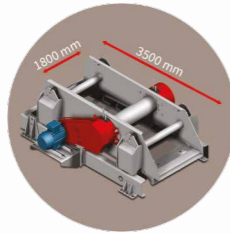

9 **REQUIRED PLACE**
Fully adjustable to your space constraints within the limits of design rules

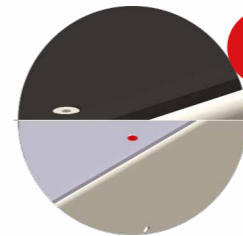

12 **PROTECTION FOR ABRASIVE PRODUCT**
• By rubberizing
• By shielding

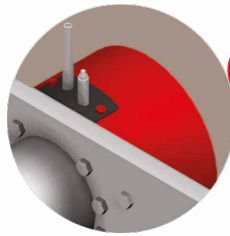

8 **LUBRIFICATION**
Grease



13 **CONTROL**
• Electrical : variable speed unit or engine-brake
• Thermal
• Hydraulic

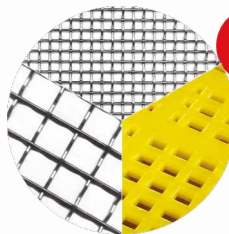

7 **EQUIPMENTS**
• Steel tightened cloths
• Stainless steel
• Polyurethane

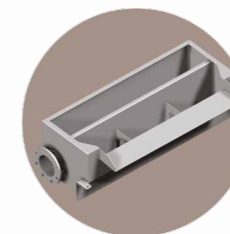

14 **FEEDING BOX**
• With inlet centered on right or left hand side
• Tailored connecting

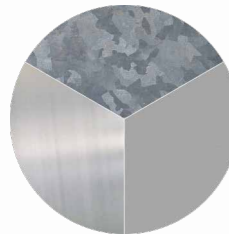

6 **FINISH**
• Galvanized
• Painted
• Pickled and passivated stainless steel

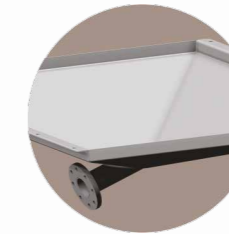

15 **COLLECTOR**
• With outlet centered or on right or left hand side
• Tailored connecting



5 **COUPLING**
• Pulleys and belts



16 **WATER SPRAYING**
• Static or vibrating



4 **ERGONOMICS**
• Space between decks
• Almost horizontal working plan



3 **SECURING EQUIPMENT**
• Longitudinal tightening

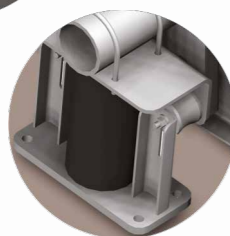

2 **SUSPENSION**
By helical springs with amplitude limiters



1 **BASE**
With adjustable slope from -5° to +5°

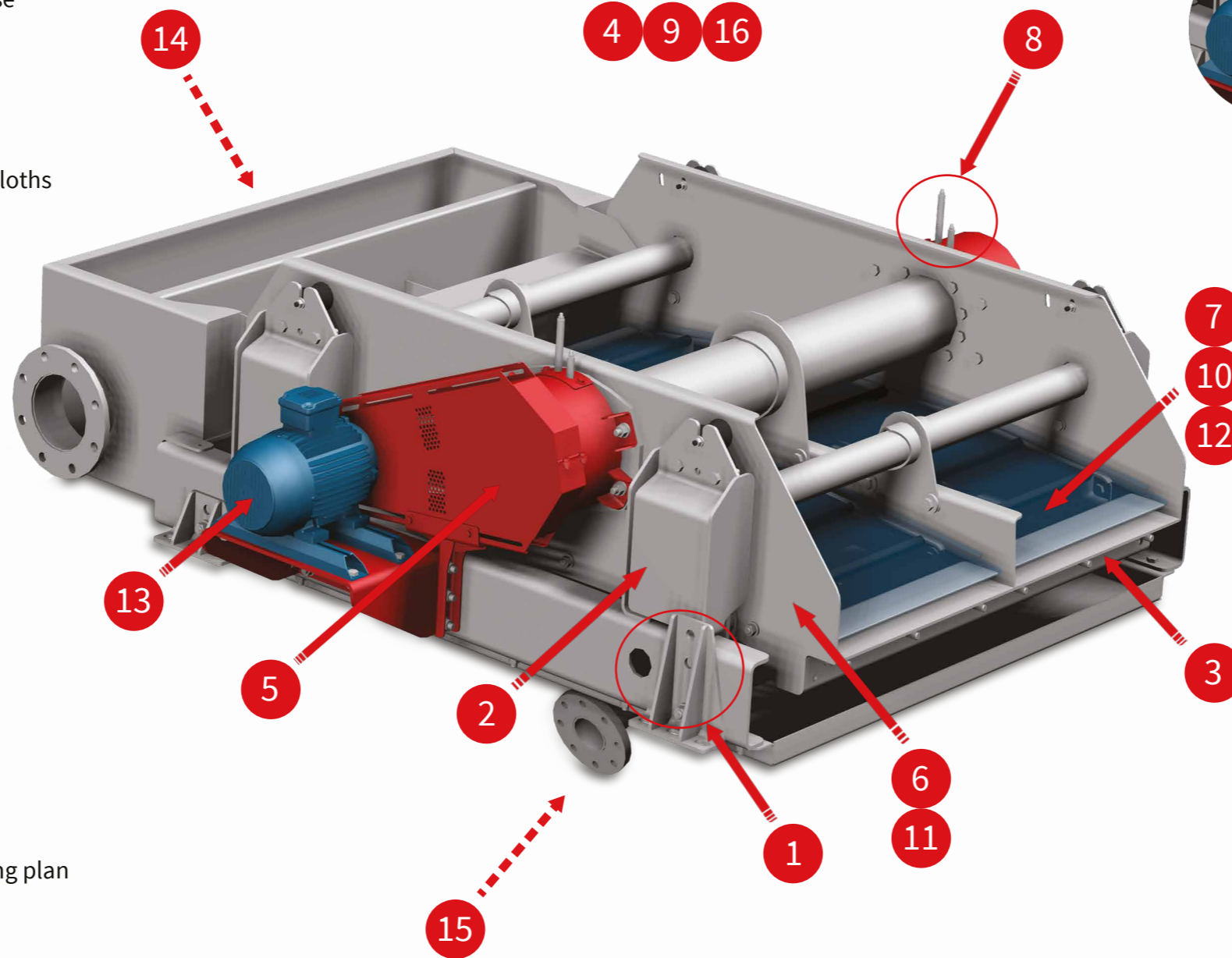

4 | HIGHLIGHTS

- PERFORMANCE
- ADJUSTMENTS (AMPLITUDE, SLOPE, ETC.)
- ECONOMIC
- SAFETY
- EFFICIENCY

5 | CHARACTERISTICS

- Surface 0.4 to 5.4 m²
- Acceleration 3.8 G
- Amplitude a few mm
- Speed 1,500 à 2,200 rpm
- Slope -5 to +5 degrees
- Number of decks 1 to 2 decks
- Cuts 0.500 to 2 mm
- Machine weight up to 1,200 kg
- Length 1,200 to 3,500 mm
- Width between sides 400 to 1,800 mm
- Driving power 2.2 kW to 5.5 kW
- Elliptical vibration in the vertical plan





6 | ADDITIONNAL EQUIPMENTS FOR THE RANGE FILTER HC

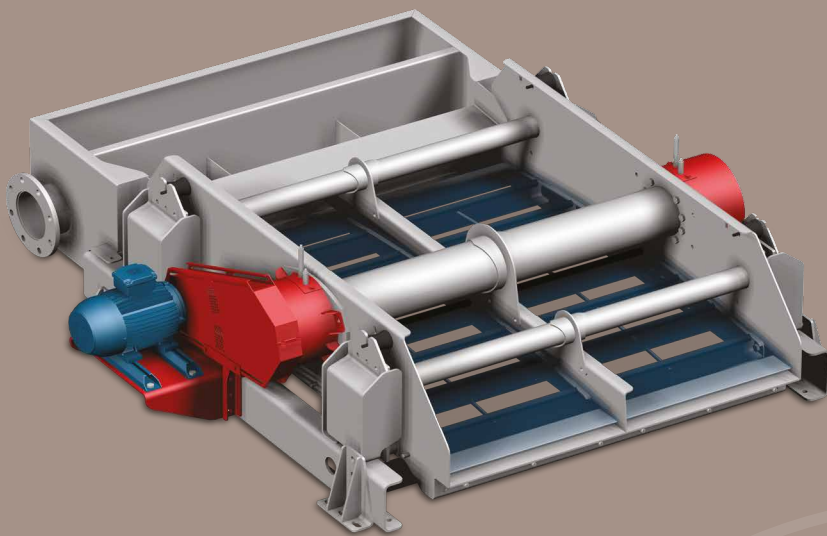

FILTER SCREEN TC

- With feeding box

FILTER SCREEN BC

- With feeding box
- With collector



www.chauvin.fr

info@chauvin.fr

Phone : +33 (0)4 76 09 30 63

Fax : +33 (0)4 76 22 30 54

Head Office

20 rue des Grands Champs

ZI La Rollandière

38360 SASSENAGE - FRANCE

PO Box

BP 70015

38044 GRENOBLE CEDEX 9 - FRANCE

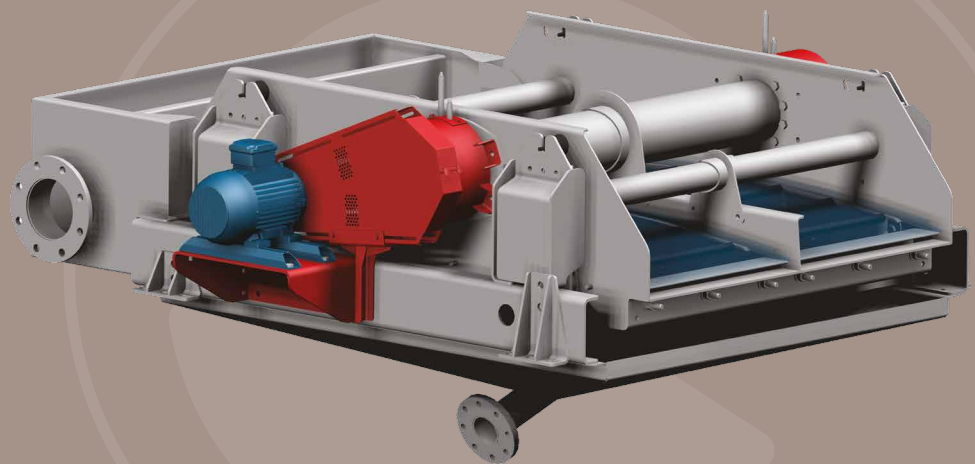

We remain at your disposal for any further information.
CHAUVIN is a subsidiary of SINEX INDUSTRIE.