

HIGH ENERGY horizontal SCREEN TRIROL®

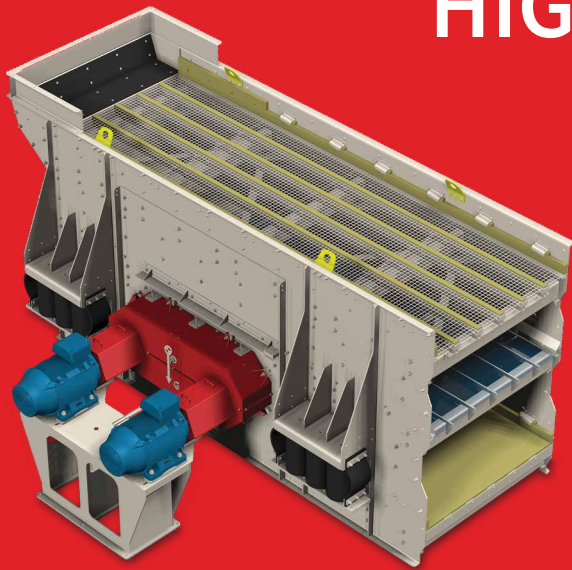

“The horizontal screen TRIROL® is designed to operate up to 8g of acceleration, for screening difficult and very sticky products of 1 to 300 mm, wet or dry. ”



1 | CUSTOMIZED DESIGN

All design criteria such as speed, cuts, particle size distribution, humidity, temperature, etc. are integrated to fit the basic parameters of our machines like the surface, the amplitude and the frequency of vibration, the slope and the correct equipment (water spraying device, special cloths, cleaning systems, etc.).

2 | APPLICATIONS

- Public works and mining industry
- Chemical
- Fertilizer industry
- Coal industry
- Wood industry
- Environment

3 | USES

- SIZING material dry or wet
- SEPARATION (of good product and particles to be eliminated)
- WASHING & RINSING
- CLASSIFYING

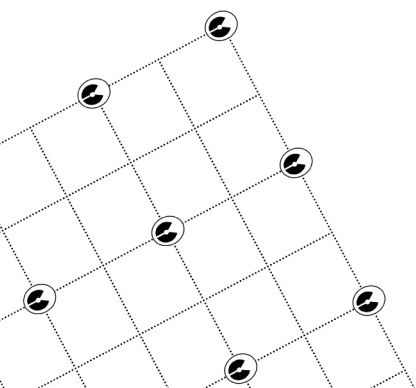

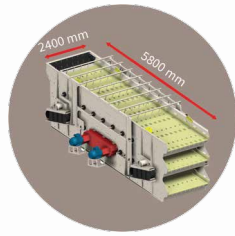

8 REQUIRED SPACE
Reduced space thanks to the horizontal position of the screen

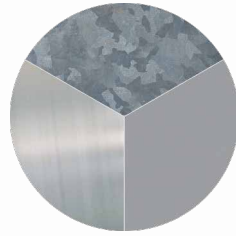

7 FINISH
• Galvanized
• Painted
• Stainless steel

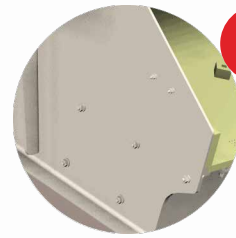

9 STATIC HOOD & VIBRATING BODY
• Bored, assembled and bolted
• Fully removable

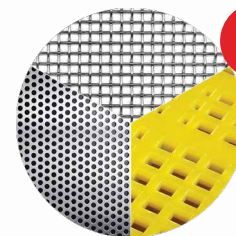

10 EQUIPMENTS
• Stainless or polyurethane tightened cloths
• Stainless steel or polyurethane modular panels
• Perforated plates

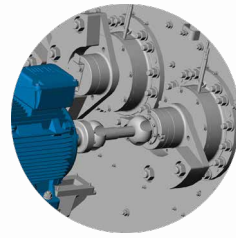

6 COUPLING
• Universal joint

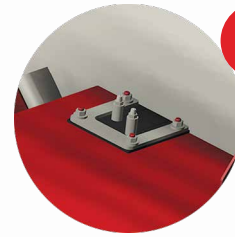

11 LUBRICATION
Grease

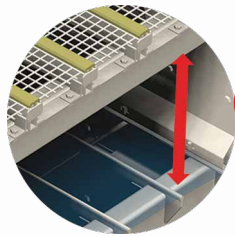

5 ERGONOMICS
• Large space between the decks till 850 mm
• Horizontal operating plane

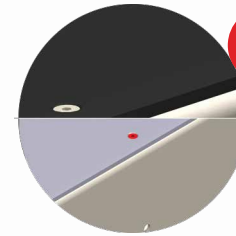

12 PROTECTION FOR ABRASIVE PRODUCT
• By rubberizing
• By shielding



4 WATER SPRAYING
• Static
• In option



13 CONTROL
• Digital control
• Variable speed unit
• Engine-brake

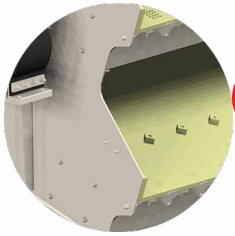
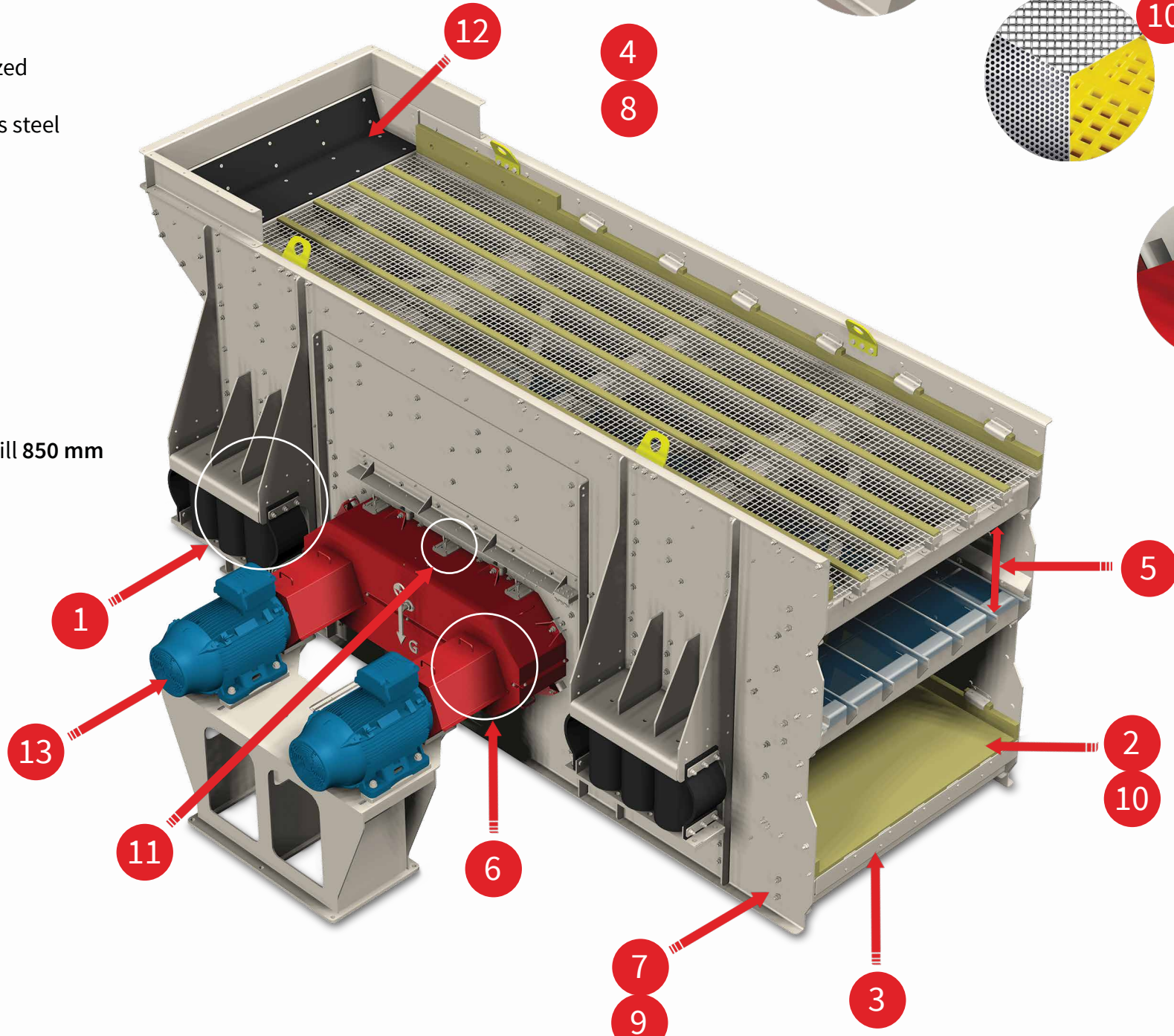

3 SUPPORT FRAME
Fully adjustable

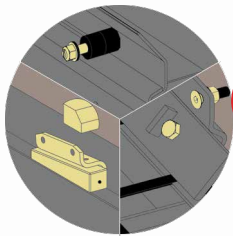

2 SECURING EQUIPMENT
• Either lateral or longitudinal tightening
• By clamping
• Either by fitting (modular panels)



1 SUSPENSION
By helical springs

4 | HIGHLIGHTS

- PERFORMANCE
- ERGONOMICS
- INCREASED PRODUCTION
- COMPACT
- INCREASED EFFICIENCY
- EFFICIENCY TO SCREEN STICKY PRODUCTS
- REDUCTION OF THE SCREEN SURFACE
- ECONOMIC

5 | CHARACTERISTICS

- Surface 3.6 up to more 15 m²
- Acceleration 7 to 8 G
- Amplitude 14 to 19 mm
- Speed 850 to 1,000 rpm
- Slope 0 to 5 degrees
- Number of decks 1 to 4 decks
- Cuts 1 to more than 300 mm
- Machine weight up to 20 tons
- Length 3,000 to 6,700 mm
- Width between sides 1,200 to 2,400 mm
- Driving power 9 kW to 37 kW
- Elliptical vibration in the vertical plane

6 | INNOVATION : DIGITAL TRIOL

The solution to difficult products

- Programming of self-cleaning sequences
- Screening settings change during operation
- Noise reduction and reduce energy consumption

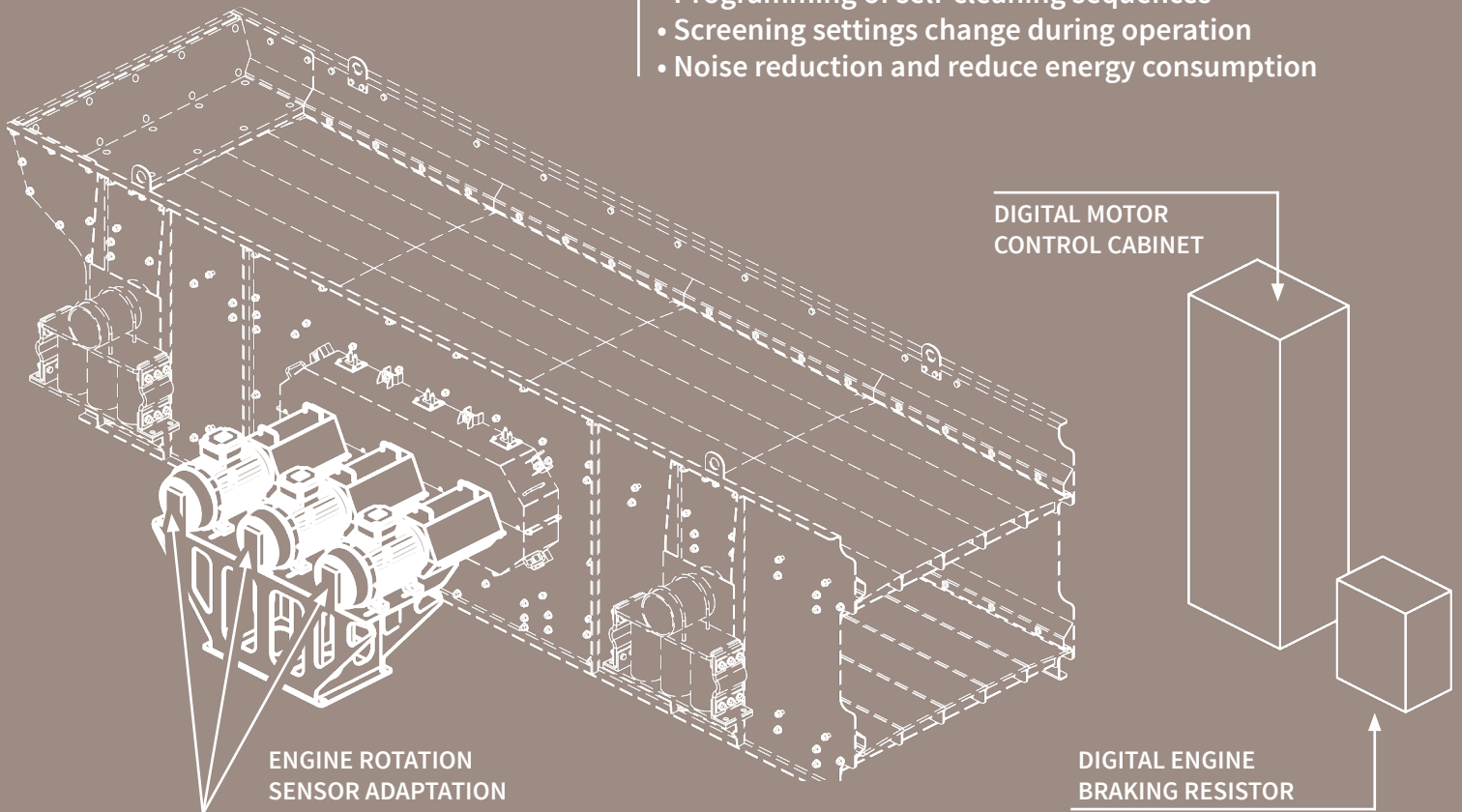

7 | COMPARATIVE OVERALL DIMENSIONS TRIOL VS ROL (for equivalent flows)

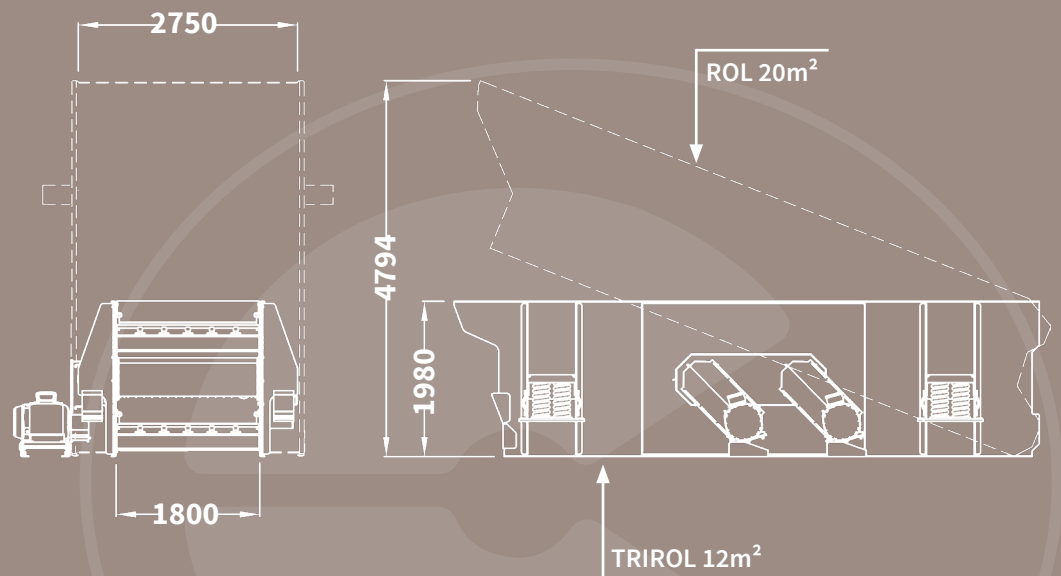

www.chauvin.fr

info@chauvin.fr

Phone : +33 (0)4 76 09 30 63

Fax : +33 (0)4 76 22 30 54

Head Office

20 rue des Grands Champs

ZI La Rollandière

38360 SASSENAGE - FRANCE

PO Box

BP 70015

38044 GRENOBLE CEDEX 9 - FRANCE

We remain at your disposal for any further information.
CHAUVIN is a subsidiary of SINEX INDUSTRIE.